

Pos.	Descrição	Material	Qtde
1	Motor elétrico IP-55	-	01
2	Alongamento	AISI 316	01
3	Paraf. Allen 5/16" x 5/16" S/C	SAE 1020	04
4	Chaveta Forma AA	AISI 316	01
5	Intermediário	ASTM A48 CL250	01
6	Parafuso sextavado	SAE 1020	04
7	Parafuso sextavado	SAE 1020	-
8	tampa de pressao selo	ASTM A48 CL250	01
9	Parafuso sextavado	SAE 1020	-
10	Anel o'ring da tampa	Borracha Nitrílica	01
11	Selo mecânico T21	-	01
12	Anel de desgaste do rotor	ASTM A536 65-45-12	01
13	Rotor	ASTM A48 CL250	01
14	Anel de desgaste carcaça	ASTM A536 65-45-12	01
15	Porca do eixo	AISI 420	01
16	Carcaça flangeada	ASTM A48 CL250	01
17	Bujão	SAE 1020	03
18	Carcaça rosca (Opcional)	ASTM A48 CL250	01

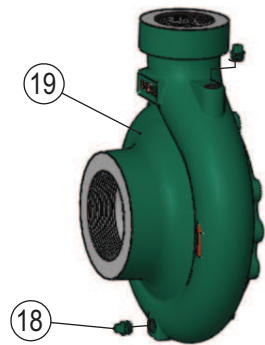

Pos.	Descrição	Material	Qtde
1	Motor elétrico IP-55	-	01
2	Chaveta Forma AA	SAE 1045	01
3	Anel o'ring	Borracha nitrílica	-
4	Bucha de Proteção eixo	AISI 304	01
5	Intermediário	ASTM A48 CL250	01
6	Parafuso sextavado	SAE 1020	04
7	Parafuso sextavado	SAE 1020	-
8	Tampa de pressão selo	ASTM A48 CL250	01
9	Parafuso sextavado	SAE 1020	-
10	Anel o'ring da tampa	Borracha Nitrílica	01
11	Selo mecânico T21	-	01
12	Anel de desgaste do rotor	ASTM A536 65-45-12	01
13	Rotor	ASTM A48 CL250	01
14	Anel de desgaste carcaça	ASTM A536 65-45-12	01
15	Semi-esfera eixo TH	AISI420/SAE1045	01
16	Parafuso allen	SAE 1020	01
17	Carcaça flangeada	ASTM A48 CL250	01
18	Bujão	SAE 1020	03
19	Carcaça rosca (Opcional)	ASTM A48 CL250	01

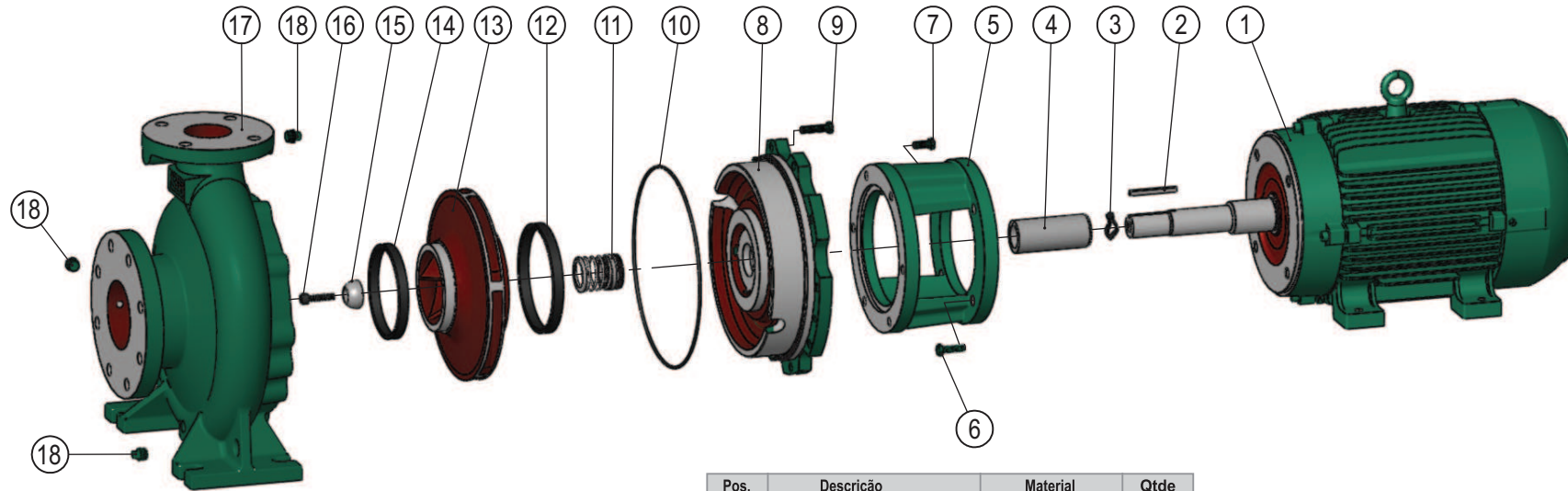

EBARA CORPORATION

Relação de Peças TH-50/125 Monobloco Selo Rosca e Flange

	Código	Descrição	1/2 CV à 1,0 CV Qtd	1,5 CV à 3,0 CV Qtd	4,0 à 7,5 CV Qtd	7,5 Monf. à 20,0 CV Qtd
MOTOR	- - -	MOTOR BLINDADO IP-55	1	1	1	1
INTERMED.	1127.04.03027	INTERMEDIARIO TH-40 (7,5CV)	1	1	1	-
	1127.04.02986	INTERMEDIARIO TH-40/TH-40R 10 A 25 CV	-	-	-	1
	1127.04.00314	PARAF.SEXT.UNC 3/8 x 1 RI	4	4	4	-
	1127.04.01104	PARAF.SEXT.UNC 1/2 x 1 1/4 RI	-	-	-	4
TAMPA PRES.	1127.04.10159	ANEL O'RING 177,47 x 2,62MM BUNA-N	1	1	1	1
	1127.04.00316	PARAF.SEXT.UNC 3/8 x 1 1/2	6	6	6	6
	1127.04.03028	TAMPA PRES.TH-32-40-50(125/160) 65(125)M/B-SELO 1.3/8	1	1	1	-
	1127.04.03136	TAMPA PRES.TH-32-40-50(125/160) 65(125)B-SELO 1.3/4	-	-	-	1
ALONG.	1127.04.03360	ALONG. TH-30 1/2 A 1 CV SELO 1.3/8T21 INOX316	1	-	-	-
	1127.04.03337	ALONG. TH-30 1,5 A 3 CV SELO 1.3/8T21 INOX316	-	1	-	-
	1127.04.05344	CHAVETA 3/16x3/16x28mm (AA) INOX 316	1	1	-	-
	1127.04.00335	PARAF. ALLEN 5/16 x 5/16 S/C	4	4	-	-
	1127.04.02844	PORCA DO EIXO TH-30 INOX 316	1	1	-	-
SELO	1127.04.10068	ANEL O'RING DIAM.25,12 X 1,78MM	-	-	1	-
	1127.04.10069	ANEL O'RING DIAM.34,65x1,78MM	-	-	-	1
	1127.04.02897	BUCHA PROTECAO DO EIXO TH-30 MONOBL. INOX 304	-	-	1	-
	1127.04.02904	BUCHA PROTECAO DO EIXO TH-80/250 MONO INOX304	-	-	-	1
	1127.04.00230	SELO MEC.1 3/8" T21 BUNA 406397/122SBP4RS	1	1	1	-
	1127.04.00229	SELO MEC.1 3/4" T21 BUNA COD.665191	-	-	-	1
ROTOR	1127.04.02688	ANEL DESG.TH-25/200R - TH-32/125R/160R/200R - TH-40/125R/160R/200R - TH-50	1	1	1	1
	1127.04.03007	ROTOR TH-50/125 142X7/8 MAN/BLOC	1	1	1	-
	1127.04.03391	ROTOR TH-50/125 142X31.75 BLOC	-	-	-	1
SEMI-ESFERA	1137.01.01561	PARAF. ALLEN 3/8 X 1.1/2	-	-	1	-
	1127.04.03081	SEMI-ESFERA Ø30	-	-	1	-
	1127.04.03077	PARAF. ALLEN 1/2" X 1.1/2" C/CAB. UNC	-	-	-	1
	1127.04.03080	SEMI-ESFERA Ø38	-	-	-	1
CARCACA	1127.04.02601	ANEL DESG.TH-50/125S/160S/200S/250S	1	1	1	1
	1127.04.00176	BUJAO 3/8" BSP PRETA	Tab.Carcaca	Tab.Carcaca	Tab.Carcaca	Tab.Carcaca
	Tab.Carcaca	CARCACA TH-50/125	1	1	1	1

Tabela de Carcaça		Modelo	Qtde Bujão
1127.04.04399	CARCACA TH-50/125(R).	ROSCA	2
1127.04.02581	CARCACA TH-50/125	FLANGE	3

Kit Contra Flange		Bocal	Qtde
1127.04.02223	CONTRA FLANGE DN-80 ANSI B16.1	SUC - 3"	1
1127.04.05552	CONTRA FLANGE ANSI DN50 125LB BSP	REC - 2"	1
1127.04.00333	PARAF.SEXT.UNC 5/8 x 2 1/2 RP	SUC/REC	8
1127.04.00348	PORCA SEXT.UNC 5/8"	SUC/REC	8
1127.04.07901	JUNTA BORRACHA P/C.FLANGE DN-80 ANSI B16.1 (2223)	SUC	1
1127.04.07894	JUNTA BORRACHA P/C.FLANGE ANSI DN50 125LB BSP (5552)	REC	1